

MASTER
Water Conditioning Corp.

Installation and Operation Manual

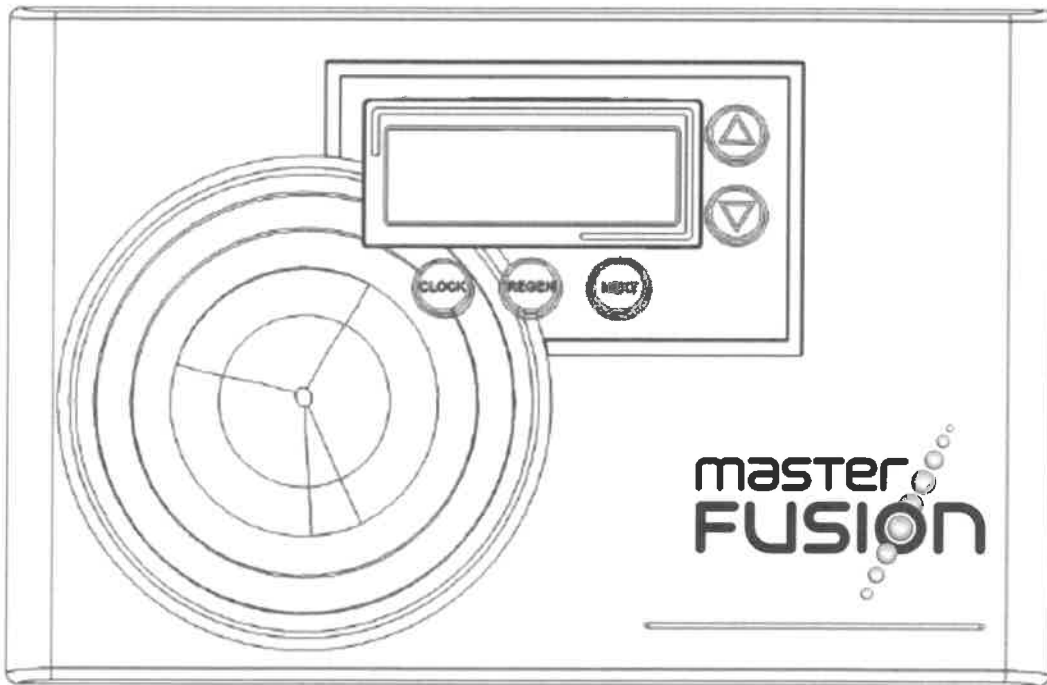

FUSION OZONE FILTER UNIT USING THE METERED MCA VALVE

January 2020 Version

Table of Contents

Model Number.....	1
Shipping Description / Unit.....	1-2
Filter Positioning.....	2
Filter Tank Loading	2
FUSION Control Valve	3-4
Ozone Generator	4
Ozone Generator Internal Layout.....	5
Ozone Generator LED Diagnostic Function	6
Service and Drain Piping.....	7-8
Schematic	9
Electrical Supply.....	10
Filling Filter with Water.....	10
FUSION Control Valve Timer Settings	11
Final Check	12
Ozone Generator Annual Maintenance.....	12
Default Timer Display and Manual Regeneration.....	13
Bypass Valve	14
Troubleshooting	15-16
Error Codes.....	17-18
FUSION Valve Parts List and Schematics	19-25
Warranty	26

Installation and Operating Instructions for
FUSION Top Mount Water Filters

Model #:

_____ FUSIONG10	1 CF Greensand Plus Filter With Ozone
_____ FUSIONG13	2 CF Greensand Plus Filter With Ozone
_____ FUSIONC10	1 CF Catalytic Carbon Filter With Ozone
_____ FUSIONC13	2 CF Catalytic Carbon Filter With Ozone
_____ FUSIONM10	1 CF Multi-Media Filter With Ozone
_____ FUSIONM13	2 CF Multi-Media Filter With Ozone
_____ FUSIONS948	1 CF Simplus Filter With Ozone
_____ FUSIONS1054	1.5 CF Simplus Filter With Ozone

Shipping Carton Description / Unit:

# of cartons	Contents	Description
1	Mineral tank	Distributor pipe installed
1	FUSION control valve	FUSION timer and backwash flow control, bypass with tailpieces, and Ozone Generator
	Filter Media	½ CF Boxes
	Filter Media	1 CF Boxes

Filter Media is Packaged as Follows:

Model #	Gravel *	Media
FUSIONG10	N/A	1 CF Greensand Plus
FUSIONG13	N/A	2 CF Greensand Plus
FUSIONC10	N/A	1 CF Catalytic Carbon
FUSIONC13	N/A	2 CF Catalytic Carbon
FUSIONM10	N/A	1 CF Multi-Media
FUSIONM13	N/A	2 CF Multi-Media
FUSIONS948	N/A	1 CF Simplus
FUSIONS1054	N/A	1.5 CF Simplus

NOTE: THIS FILTER IS NOT INTENDED TO BE USED FOR TREATING WATER THAT IS MICROBIOLOGICALLY UNSAFE OR OF UNKNOWN QUALITY WITHOUT ADEQUATE DISINFECTION WHETHER BEFORE OR AFTER THE SYSTEM.

Filter Positioning:

1. Place filter in desired position, far enough from walls and other obstructions to allow for servicing the unit.
2. Place the filter within reasonable access to a grounded 115V/60 HZ circuit and a legal drain line connection.

Filter Tank Loading:

1. Remove yellow caplug from top of tank. DO NOT CUT white riser tube. Tube was prefitted at the factory.
2. The distributor is permanently attached to the vortech---centering is not necessary. The top of the distributor will be 5/8" above the top of the tank (this was prefitted at the factory).
3. Cover the top opening of the distributor pipe before filling the tank with media.
4. Pour the media provided with the unit into the top of the tank. See page one for your specific model number unit to determine the amount of media to load into the mineral tank.

NOTE: SEE CHART AND FIGURE BELOW IF INSTALLING A FUSIONM10/13

Model #	Gravel*	1 Sand	0 Sand	45 Sand	0 Sand	Philterkol
FUSIONM10	N/A	12 lbs.	8 lbs.	25 lbs.	17 lbs.	13 lbs.
FUSIONM13	N/A	25 lbs.	16 lbs.	50 lbs.	35 lbs.	25 lbs.

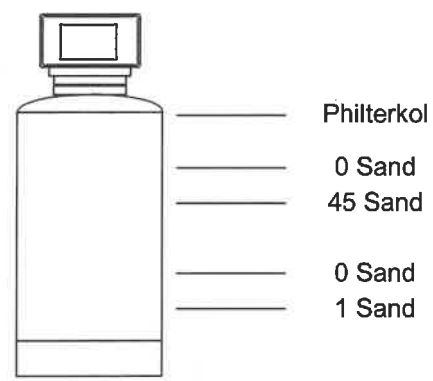

5. Remove the material used to cover the top opening of the distributor pipe.

FUSION Control Valve:

1. When facing the front of the FUSION timer, the inlet connection is located on the right and the outlet connection is on the left. The control valve's inlet and outlet connections are either 1" copper or PVC equipped with split ring and nut.

Control Valve

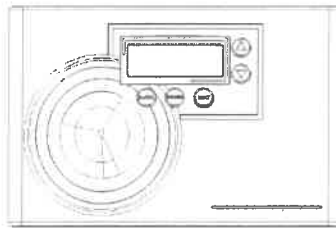

Front View

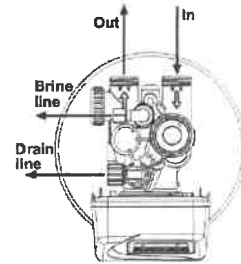

Top View

2. Turn the control valve upside down and ensure that the control valve distributor o'ring is in place. Use silicone lubricant on the o'ring.

****DO NOT USE PETROLEUM!****

****USE ONLY SILICONE ****

3. Place the control valve onto the distributor pipe and into the tank opening.
4. Thread the control valve hand tight . Do not overtighten.
8. Locate the bypass valve assembly that is packaged with the control valve. The bypass valve has two red handles that indicate flow direction, two threaded connections for the tail piece kit and two o'ring seal connections with nuts for the control valve. Align the insert connection ends with o'ring seals and nuts to the inlet and outlet connections of the control valve. Hand tighten the nuts. **DO NOT OVERTIGHTEN THE NUT!**

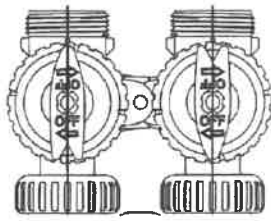

Bypass Valve

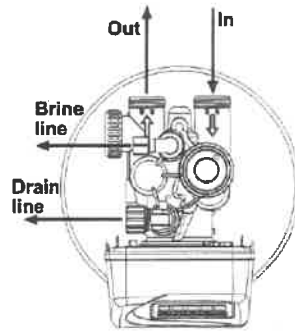

Control Valve

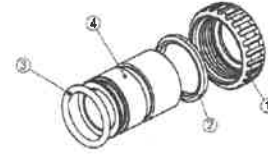

Tail piece assembly

9. Locate the tail piece kit that is packaged with the control valve. The standard tail piece kit is 1" copper with optional 1" / 3/4" PVC or 3/4" copper kits available as a special order. Each tail piece, o'ring, split ring and nut is presassembled at the factory. Align a tail piece assembly to the bypass valve threaded inlet and insert until the nut can be tightened. Hand tighten the nut because excessive tightening will damage the assembly. **REPEAT THE PROCEDURE FOR THE OUTLET CONNECTION.**

Ozone Generator:

1. Make sure the black tubing from the ozone generator (the blue box on the right of the control valve) is properly inserted into the brine elbow.
2. Connect the ozone generator power supply chord to the Power Jack on the ozone generator box. The connection is located on the back, center of the ozone generator box, nearby the air draw tubing with the air stone.
3. Connect the ozone generator power supply to an appropriate electrical outlet.
4. The ozone generator is activated during the brine/slow rinse cycle of regeneration, and will leave a pocket of air/ozone in the top of the tank.

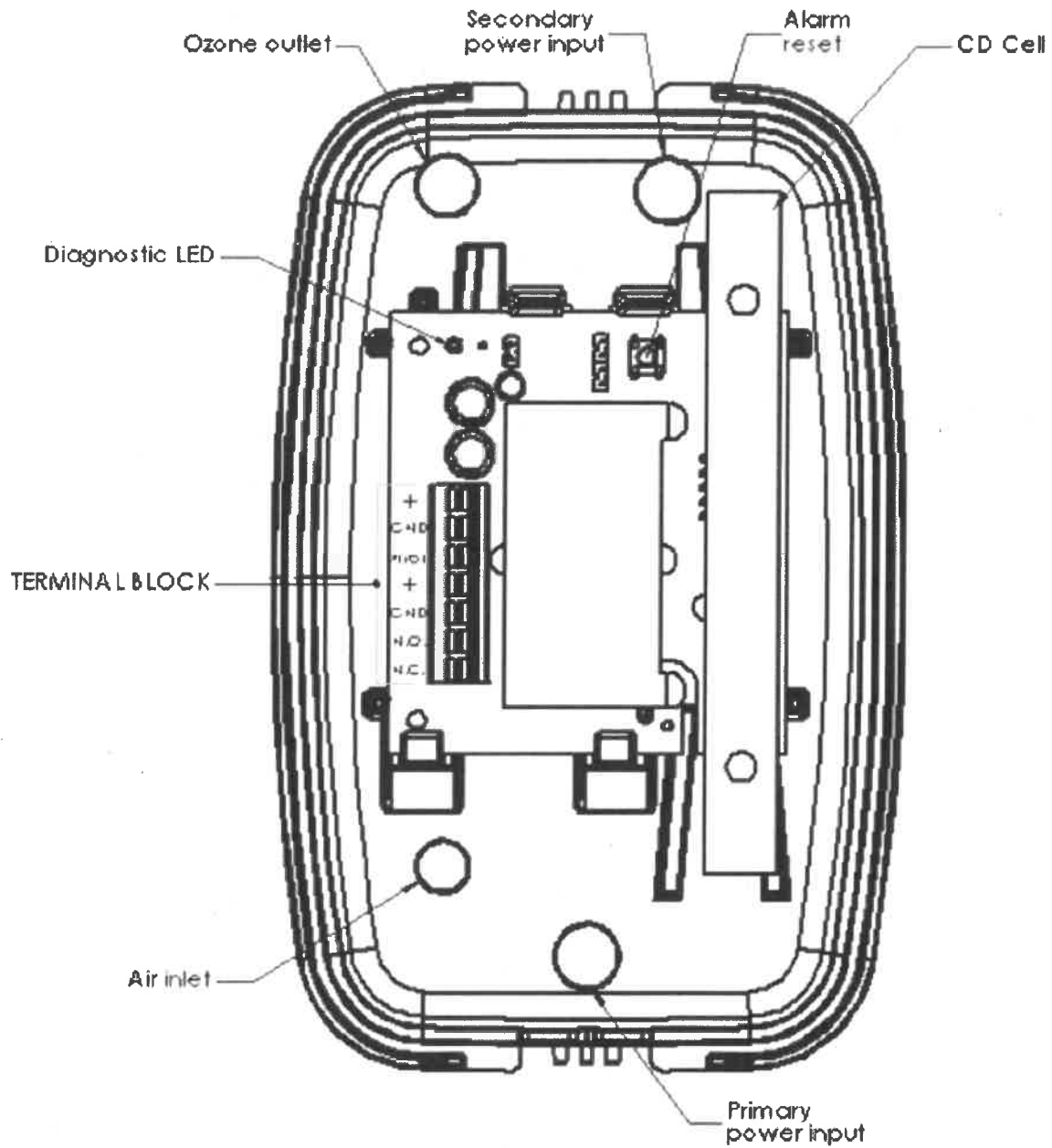

EOG Internal Layout

The EOG will automatically turn on and off by the Clack control PCB defined timing schedule. The EOG control board utilizes an onboard diagnostic LED light to convey real-time performance status of the unit. The control board within the EOG has several inputs and outputs. The following will address functions of the diagnostic LED, control input, and auxiliary outputs.

LED Diagnostic Functions:

Green Light Blinking Slowly: Standby mode; unit is powered, pilot input is OFF.

Green Light Blinking Quickly: High voltage startup (up to 3 seconds).

Green Light Solid: High voltage is ON & stable; CD cell producing ozone.

Red Light Solid: Unstable operation; CD cell may need cleaning

Green/Red Light Alternating Twice/Second: HV is ON, but operating current is low. If persistent, CD cell may need cleaning.

Red Light Flashing: NO or NC contacts are shorted. Remove short condition.

Orange Light: 1 year timer has expired; clean CD cell, then reset timer by pressing red "alarm reset" button on PCB once.

Service and Drain Piping:

1. Pipe filter into the service lines .The inlet and outlet connections of the control valve are 1" copper or PVC and are located on the back of the valve body. As you face the timer the inlet is on the right and the outlet is on the left. Always follow local plumbing codes when installing our water treatment equipment.
2. If sweat fittings are used, be sure soldering is done in such a manner as not to allow heat to reach the control valve or bypass. (If Schedule 80 PVC is used make sure to follow the proper primer and solvent instructions.)
3. The drain line connection is 5/8" OD or 3/4" npt and is located on the top left of the valve as you face the timer. It is recommended you install a 3/4" union on the drain line for servicing if not using 5/8 OD. The drain line must be of adequate size to allow for full regeneration flow.

NOTE: DUE TO THE PRESENCE OF AIR IN THE BRINE ELBOW CHAMBER OF THE CONTROL VALVE, THERE MAY BE A MINOR BURST OF AIR OUT OF THE BRINE ELBOW CHAMBER WHEN REMOVING THE BRINE ELBOW.

NOTE: MAKE SURE THE DRAIN LINE IS PROPERLY SECURED IN PLACE. IF THERE IS REMAINING AIR/OZONE IN THE MINERAL TANK, THE AIR/OZONE WILL BE FORCED THROUGH THE DRAIN LINE AT THE START OF THE REGENERATION. IF WATER HAMMER BECOMES AN ISSUE, AN AIR-BLEED VALVE ACCESSORY IS AVAILABLE FOR PURCHASE.

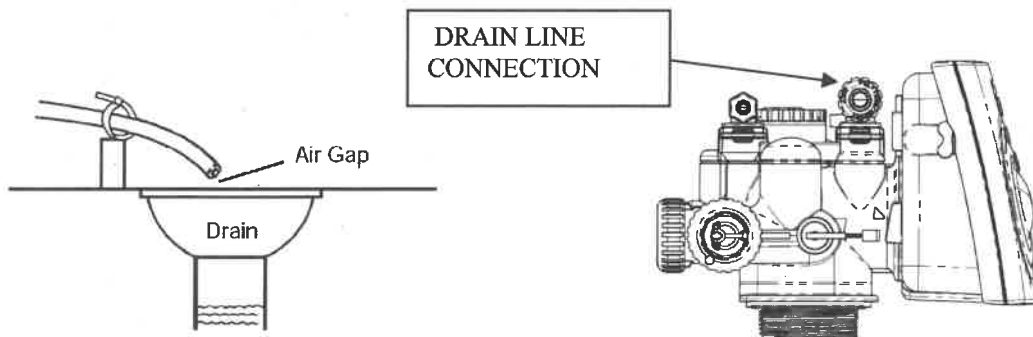

- The control valve drain connection is 3/4" npt.
- Never decrease the drain piping size to below the drain connection size.
- Maximum drain line length is 30 feet with proper sloping the entire length.
- Maximum drain line height is 6 feet above the control valve.
- The drain line must be piped to an open air gap. (See Figure above)
- Always follow local plumbing codes.

UNDER NO CIRCUMSTANCES SHOULD THERE BE A DIRECT CONNECTION WITH SANITARY SEWAGE FACILITIES.



MASTER
Water Conditioning Corp.

**TYPICAL PIPING LAYOUT FOR
CLR SERIES FILTERS**

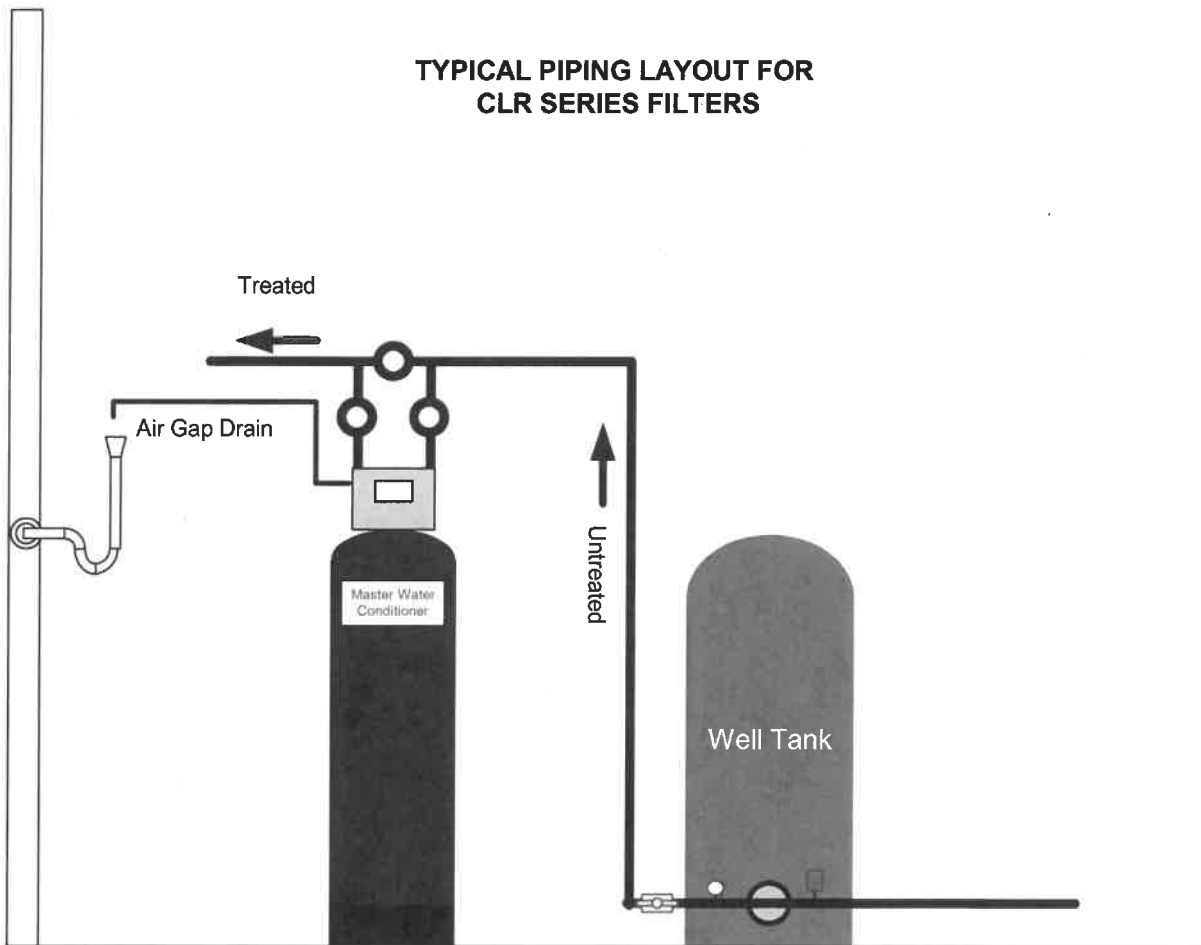

NOTE: All Master Water Conditioners must be installed after the well tank or water meter if its public water supply.

Temperature : **MAX: 120 F, MIN: 34F**
Pressure: MAX: 100 PSI, MIN: 20 PSI
Electrical: 115V/ 60 HZ

Electrical Requirements:

Always follow all local electrical codes when installing our water treatment equipment.

1. Provide an 115v/60Hz properly grounded dedicated electrical Outlet. (It's very important that the polarity be correct)
Avoid using outlets that are switch controlled.
2. Maximum amperage required is 5 amps.
3. Make sure the electrical service provides power 24 hours per day. We recommend installing a **surge protector** to protect unit from power surges, which are not covered by warranty.

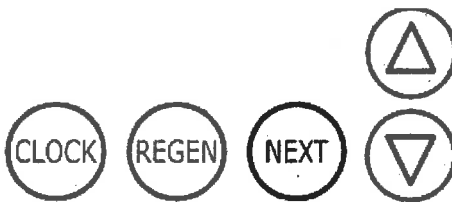

Filling Filter with Water:

1. Connect the FUSION control valve transformer into the electrical outlet provided.
2. Press and hold the REGEN button until the drive motor starts. When the drive motor stops, the display will read "BACKWASH" position.
3. Open the inlet ball valve a ¼ turn of its full open position to allow water to enter the water softener mineral tank slowly. The water is going to enter the tank from the bottom of the distributor pipe and leave the tank from the top. This will slowly purge all the air from the tank.

IF WATER ENTERS THE TANK TOO FAST, ALL THE CATION RESIN WILL BE FLUSHED TO DRAIN DURING START UP.

4. When only water is running to the drain, open the inlet and outlet ball valves fully.
5. Press the REGEN again until the drive motor starts. When the drive motor stops, the display will read "BRINE" position.
6. The control valve will automatically advance to the service position once the BRINE cycle has finished.

FUSION Control Valve Timer Settings:

Note: The control valve is set at the factory. You only need to set the time of day , hardness and regeneration time if required, which is preset at 2 am.

Time of Day Setting

- 1) Press the CLOCK button. The screen will show the Time of Day in blinking numbers.
- 2) To change the Time of Day, use the UP and DOWN arrows to set the Hour.
- 3) To change the Minutes, press the CLOCK button, and use the UP and DOWN arrows to set the Minutes
- 4) Press the CLOCK button.

Hardness Setting (the factory default is 10)

- 1) Press the NEXT and UP arrow, hold for 3 seconds. The screen will show the Hardness as grains per gallon in blinking numbers.
- 2) To change the number, use the UP or DOWN arrows.
- 3) Press the NEXT button.

**To calculate the hardness setting, use the following formula:
Hardness Setting = (Iron x 5) + (Manganese x 10) + (Hydrogen Sulfide x 28)**

Regeneration Day Override Setting (the factory default is 3)

- 1) The screen will show the Regeneration Day Override in blinking numbers.
- 2) If the unit is being used as the primary iron treatment device, set the day override according to the following:
- 3) To change the number, use the UP or DOWN arrows.
- 4) Press the NEXT button.

Time of Regeneration Setting (the factory default is 1 AM)

- 1) The screen will show the Time of Regeneration in blinking numbers.
- 2) If Regeneration time change is desired, use the UP or DOWN arrows to set the hour.
- 3) Press the NEXT button, and use the UP or DOWN arrows to set the minutes.

4) Press the NEXT button.

NOTE: THE CAPACITY IS PRESET AT THE FACTORY.

Final Check:

1. Make sure the drain line connection meets all plumbing codes and that the drain line size can handle the backwash flow rate of the softener.
2. Make sure the drain line is properly secured in place.
3. Make sure the Inlet and Outlet on bypass valve are open.
4. Make sure the control valve timer and ozone generator are plugged into an electrical outlet with power 24 hours per day.
5. Check all piping for leaks.

EOG Annual Maintenance and Reset:

1. After 365 days of operation the EOG II LED light will flash orange to indicate that the EOG needs to be serviced.
2. Replace the brine line check valve.
3. Clean the corona discharge cell.
4. Reset timer by pressing red "alarm reset" button on the ozone generator circuit board once.

Manual Regeneration:

To initiate manual regeneration immediately, press and hold the "REGEN" button for three seconds. The system will begin to regenerate immediately. **The request cannot be cancelled.**

To initiate a manual regeneration at the preset delayed regeneration time, when the regeneration time option is set to "NORMAL" or "NORMAL + on 0", press and release "REGEN". The words "REGEN TODAY" will flash on the display to indicate that the system will regenerate at the preset delayed regeneration time. If you pressed "REGEN" in error, pressing the button again will cancel the request.

Note: If the regeneration time option is set to "on 0" there is no set delayed regeneration time so "REGEN TODAY" will not activate if "REGEN" button is pressed.

Power Loss

If the power goes out for less than two hours, the system will automatically reset itself. If an extended power outage occurs, the time of day will flash on and off which indicates the time of day should be reset. The system will remember the rest.

Error Message

If the word "ERROR" and a number are alternately flashing on the display, contact a service technician for help. This means the valve is unable to function properly. (See page 21)

BYPASS VALVE OPERATION

Figure 1

NORMAL OPERATION

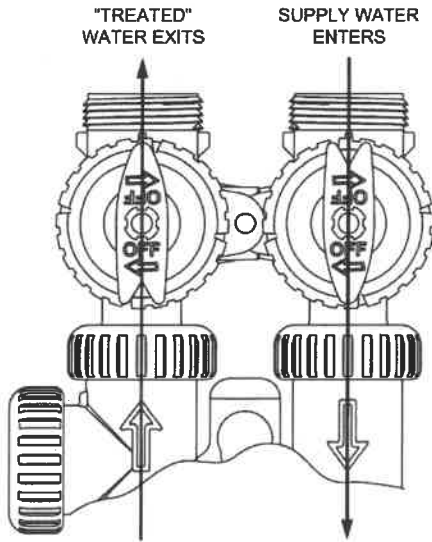

Figure 2

BYPASS OPERATION

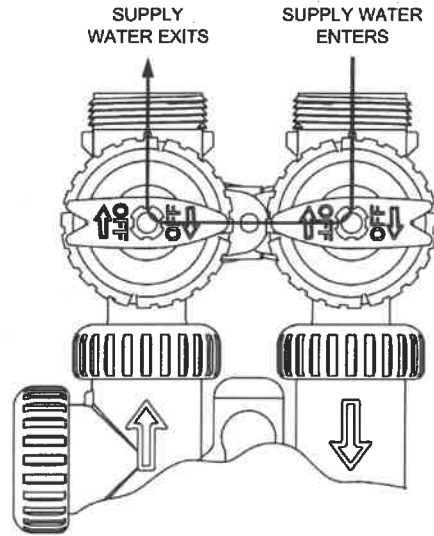

Figure 3

DIAGNOSTIC MODE

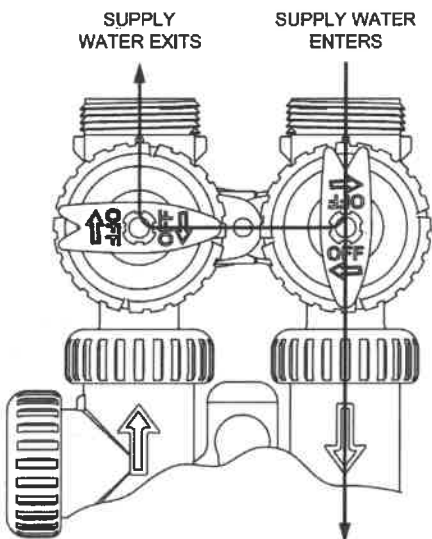
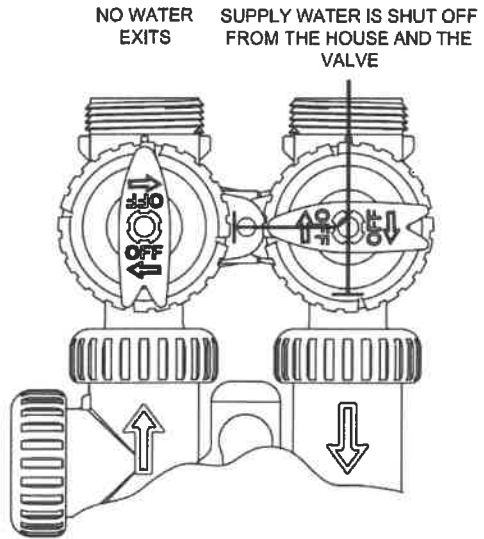

Figure 4

SHUT OFF MODE



Troubleshooting

Symptom: Water conditioner fails to regenerate.

Possible Cause	Solution
Power supply to FUSION control has been interrupted.	Determine reason for power interruption and correct. Reset time of day.
Water pressure lost	Restore water pressure.
Control valve has incorrect program values.	Reset values.
Meter clogged	Remove meter and clean.
Defective control.	Replace control assembly.
Manual bypass valve is open.	Close manual bypass valve.
Leak at riser pipe seal	Insure that riser pipe is properly sealed at o'ring seal. Inspect pipe for cracks.
Plugged injector or injector screen	Inspect and clean injector and/or injector screen.

Symptom: No Ozone Draw

Possible Cause	Solution
Plugged injector or injector screen	Inspect and clean injector and/or injector screen.
Insufficient water pressure	Increase water pressure above 25 psig (172kPa) minimum.
Obstructed drain line	Remove obstruction.

Problem: Leak to Drain

Possible Cause	Solution
No flow control installed in drain line.	Install drain line flow control.
Insufficient water pressure.	Increase water pressure above 25 psig (172kPa) minimum.

Symptom: Loss of Media to Drain

Possible Cause	Solution
No flow control installed in drain line	Install drain line flow control.

Symptom: Loss of Water Pressure

Possible Cause	Solution
Fouled softener media bed due to iron accumulation or chlorine.	Replace media bed.
Slots in riser pipe or laterals are filled with softener media fines.	Inspect and clean distributor pipe slots as needed.

ERROR CODES

ERROR DESCRIPTIONS

(V3890MP-02 BOARD with 5800.0 Software)

101	UNABLE TO START. Control not sensing valve movement with motor output energized.
102	#1 MAV/Stager #1 MOTOR STALLED. Unable to find proper park position.
103	#1 MAV/Stager #1 MOTOR RAN TOO LONG. Unable to find proper park position.
104	#1 MAV/Stager #1 VALVE HOMING. Control unable to find the HOME position of the valve
106	#2 MAV/Stager #2 MOTOR RAN TOO LONG. Unable to find proper park position.
107	#2 MAV/Stager #2 MOTOR STALLED. Unable to find proper park position.
109	INVALID MOTOR STATE Control can no longer operate due to the detection of an invalid motor state.
116	#3 MAV/Stager #3 MOTOR RAN TOO LONG. Unable to find proper park position.
117	#3 MAV/Stager #3 MOTOR STALLED. Unable to find proper park position.
126	#4 MAV/Stager #4 MOTOR RAN TOO LONG. Unable to find proper park position.
127	#4 MAV/Stager #4 MOTOR STALLED. Unable to find proper park position.
201	INVALID REGEN STEP Control can no longer operate due to the detection of an invalid regeneration cycle step (Internal software error)
402	POWER DOWN MEMORY Control can no longer operate due to a <u>check sum error</u> for the operational data and status section memory
403	PROGRAM MEMORY. Control can no longer operate due to a <u>check sum error</u> for the programming section memory
404	DIAGNOSTIC MEMORY Control can no longer operate due to a <u>check sum error</u> for the diagnostic section memory
405	HISTORY MEMORY Control can no longer operate due to a <u>check sum error</u> for the history section memory
406	CONTACT MEMORY Control can no longer operate due to a <u>check sum error</u> for the contact screen section memory.

- 407 STATUS RAM MEMORY FAILURE Control can no longer operate due to corrupted data detected in the operational and status section. Once generated the error mode is not entered nor an error display viewed.
Instead previous (<6 hours) data is used
- 408 DIAGNOSTIC RAM MEMORY FAILURE Control can no longer operate due to corrupted data detected in the diagnostic section. Once generated, the error mode is not entered nor an error display viewed.
Instead previous (<6 hours) data is used.
- 410 CONFIG DOWNLOAD Configurator file downpoaded to the control was not originally uploaded from another control with the identical software.

Refill Flow Control Assembly and Refill Port Plug

Drawing No.	Order No.	Description	Quantity
1	V3195-01	WS1 Refill Port Plug Asy	This part is required for backwash only systems
2	H4615	Elbow Locking Clip	1
3	H4628	Elbow 3/8" Liquifit	1
4	V3163	O-ring 019	1
5	V3165-01*	WS1 RFC Retainer Asy (0.5 gpm)	1
6	V3182	WS1 RFC	1
7	V4144-01	Elbow 3/8" Liquifit Asy w/RFC	1
Not Shown	V3552	WS1 Brine Elbow Asy w/RFC	Option
Not Shown	H4650	Elbow 1/2" with nut and insert	Option

*Assembly includes V3182 WS1 (0.5 gpm) RFC.

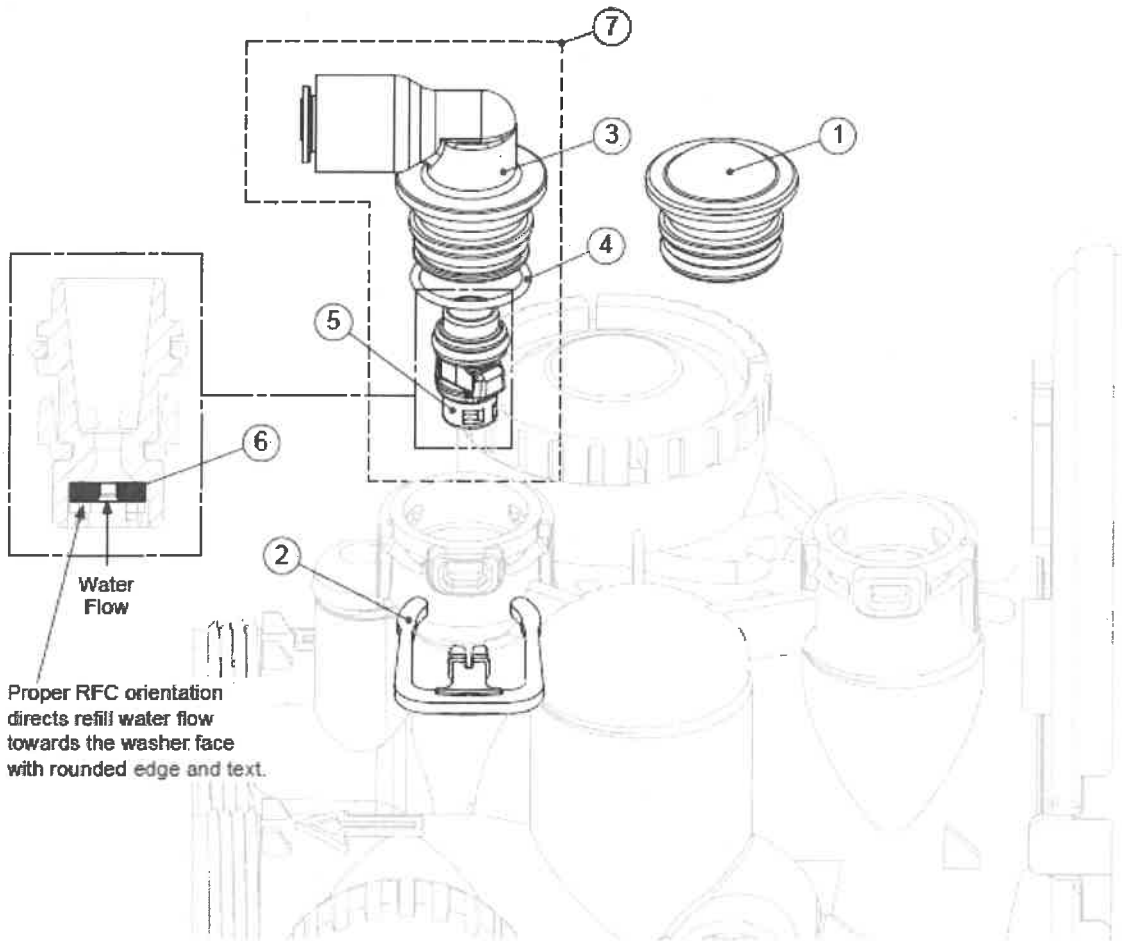

Drain Line – 3/4"

Drawing No.	Order No.	Description	Quantity
1	H4615	Elbow Locking Clip	1
2	PKP10TS8-BULK	Polytube insert 5/8	Option
3	V3192	WS1 Nut 3/4 Drain Elbow	Option
4*	V3158-01	WS1 Drain Elbow 3/4 Male	1
5	V3163	O-ring 019	1
6*	V3159-01	WS1 DLFC Retainer ASY	1
7	V3162-007	WS1 DLFC 0.7 gpm for 3/4	One DLFC must be used if 3/4 fitting is used.
	V3162-010	WS1 DLFC 1.0 gpm for 3/4	
	V3162-013	WS1 DLFC 1.3 gpm for 3/4	
	V3162-017	WS1 DLFC 1.7 gpm for 3/4	
	V3162-022	WS1 DLFC 2.2 gpm for 3/4	
	V3162-027	WS1 DLFC 2.7 gpm for 3/4	
	V3162-032	WS1 DLFC 3.2 gpm for 3/4	
	V3162-042	WS1 DLFC 4.2 gpm for 3/4	
	V3162-053	WS1 DLFC 5.3 gpm for 3/4	
	V3162-065	WS1 DLFC 6.5 gpm for 3/4	
	V3162-075	WS1 DLFC 7.5 gpm for 3/4	
V3162-090	WS1 DLFC 9.0 gpm for 3/4		
	V3162-100	WS1 DLFC 10.0 gpm for 3/4	

*4 and 6 can be ordered as a complete assembly - V3331 WS1 Drain Elbow and Retainer Asy

Valves are shipped without drain line flow control (DLFC) - install DLFC before using. Valves are shipped without 3/4 nut for drain elbow (polytube installation only) and 5/8" polytube insert (polytube installation only).

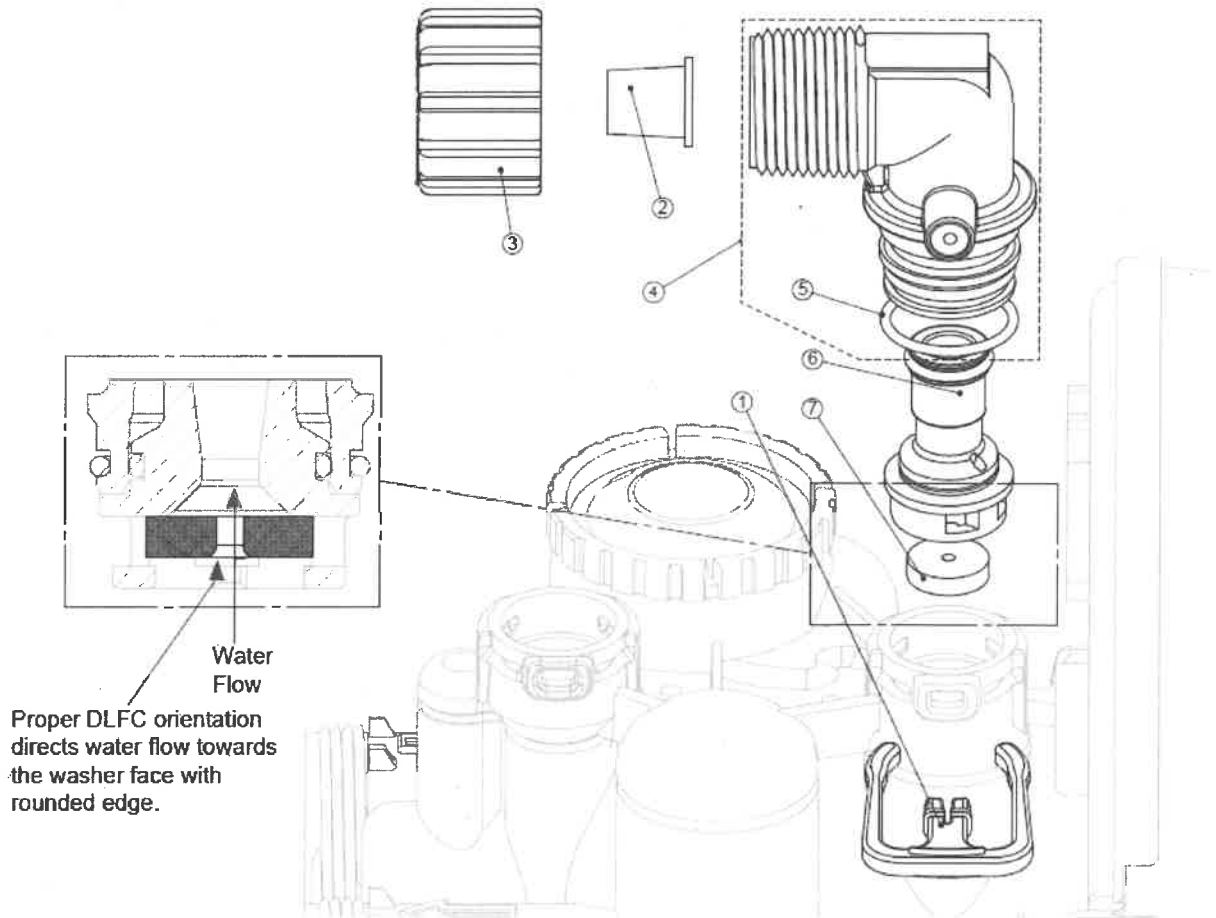

Water Meter, Meter Plug and Mixing Valve

Drawing No.	Order No.	Description	Quantity
1	V3151	WS1 Nut 1" QC	1
2	V3003*	WS1 Meter ASY	1
3	V3118-01	WS1 Turbine ASY	1
4	V3105	O-ring 215	1
5	V3003-01	WS1 Meter Plug ASY	1
6	V3013	Mixing Valve	Optional

*Order number V3003 includes V3118-01 WS1 Turbine ASY and V3105 O-ring

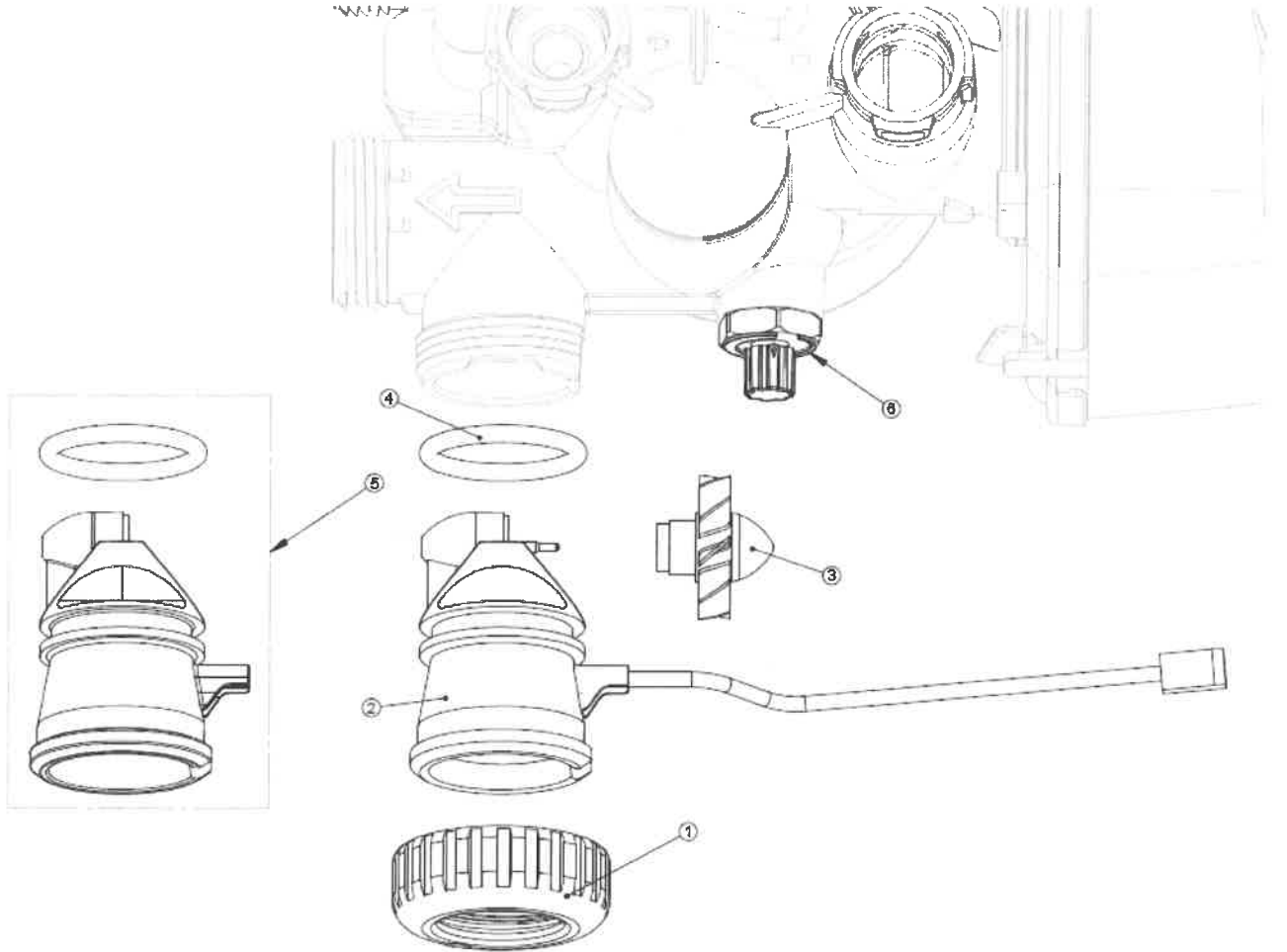

THIS WATER METER SHOULD NOT BE USED AS THE PRIMARY MONITORING DEVICE FOR CRITICAL HEALTH EFFECT APPLICATIONS.

NOTE: A water meter is not applicable for a TC control valve.

Bypass Valve

Drawing No.	Order No.	Description	Quantity
1	V3151	WS1 Nut 1" Quick Connect	2
2	V3150	WS1 Split Ring	2
3	V3105	O-Ring 215	2
4	V3145	WS1 Bypass 1" Rotor	2
5	V3146	WS1 Bypass Cap	2
6	V3147	WS1 Bypass Handle	2
7	V3148	WS1 Bypass Rotor Seal Retainer	2
8	V3152	O-ring 135	2
9	V3155	O-ring 112	2
10	V3156	O-ring 214	2

(Not Shown) Order No. V3191-01, Description: WS1 Bypass Vertical Adapter Assembly

Order No.	Description	Quantity
V3151	WS1 Nut 1" Quick Connect	2
V3150	WS1 Split Ring	2
V3105	O-Ring 215	2
V3191	WS1 Bypass Vertical Adapter	2

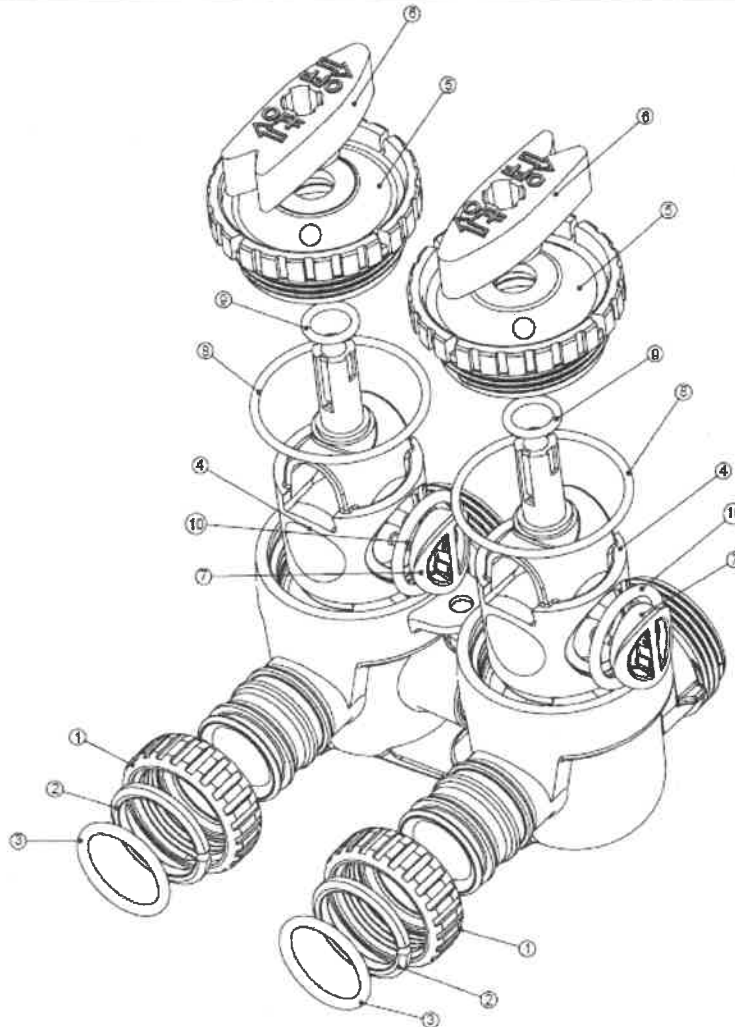

MP Front Cover and Drive Assembly

Drawing No.	Order No.	Description	Quantity
1	V3371-01	WS1MR FRONT COVER ASSEMBLY	1
2	V3107-01	WS1 MOTOR	1
3	V3106-01	WS1 DRIVE BRACKET & SPRING CLIP	1
4	V3890MP-02BOARD	WS1THRU2L/2 MP PCB XMEGA REPLACE	1
5	V3110	WS1 DRIVE REDUCING GEAR 12X36	3
6	V3109	WS1 DRIVE GEAR COVER	1
NOT SHOWN	V3186	WS1 AC ADAPTER 120V-12V	1
	V3186-01	WS1 AC ADAPTER CORD ONLY	
NOT SHOWN	V3372	WS1MR DRIVE BACK PLATE	1
NOT SHOWN	V3463	WS1MR QUARTER TURN FASTENERS	2
NOT SHOWN	V3466	O-RING 008	2

Refer to Control Valve Service Manual for other drawings and part numbers.

AC Adapter	U.S.
Supply Voltage	120 V AC
Supply Frequency	60 Hz
Output Voltage	12 V AC
Output Current	500 mA

Relay Specifications: 12V DC Relay with a coil resistance not less than 80 ohms. If mounting the relay under the cover check for proper mounting location dimensions on the backplate.

Wiring For Correct On/Off Operation	
PC Board Relay Terminal Block	Relay
RLY 1	Coil -
V +	Coil +
RLY 2	Coil -

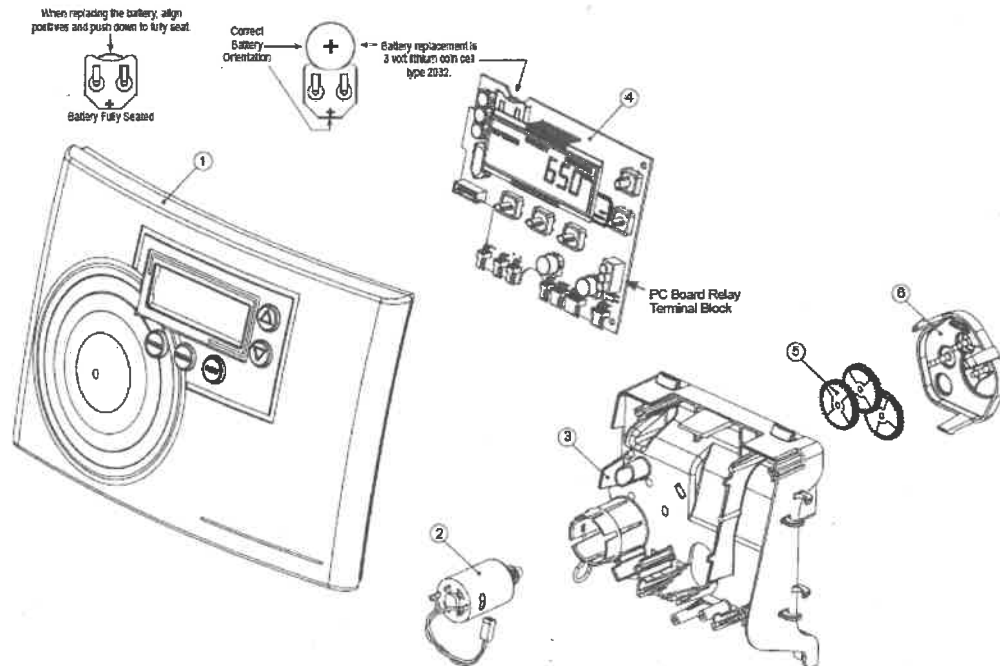

Drawing No.	Order No.	Description	Quantity
1	V3005	WS1 Spacer Stack Assembly	1
2	V3004	Drive Cap ASY	1
3	V3372	WS1MR Drive Back Plate	1
4	V3011	WS1 Piston Downflow ASY	1
5	V3174	WS1 Regenerant Piston	1
6	V3135	O-ring 228	1
7	V3180	O-ring 337	1
8	V3105	O-ring 215 (Distributor Tube)	1
9	V3466	O-ring 008	2
10	V3463	WS1MR Quarter Turn Fasteners	2
Not Shown	V3001	WS1 Body ASY Downflow	1
	V3001-02	WS1 Mixing Valve Body ASY	
	V3001UP	WS1 Body ASY Upflow	
	V3001-02UP	WS1 Mixing Valve Body Upflow ASY	
Not Shown	V3013	WS1 Mixing Valve ASY	1

Note: The regenerant piston is not used in backwash only applications.

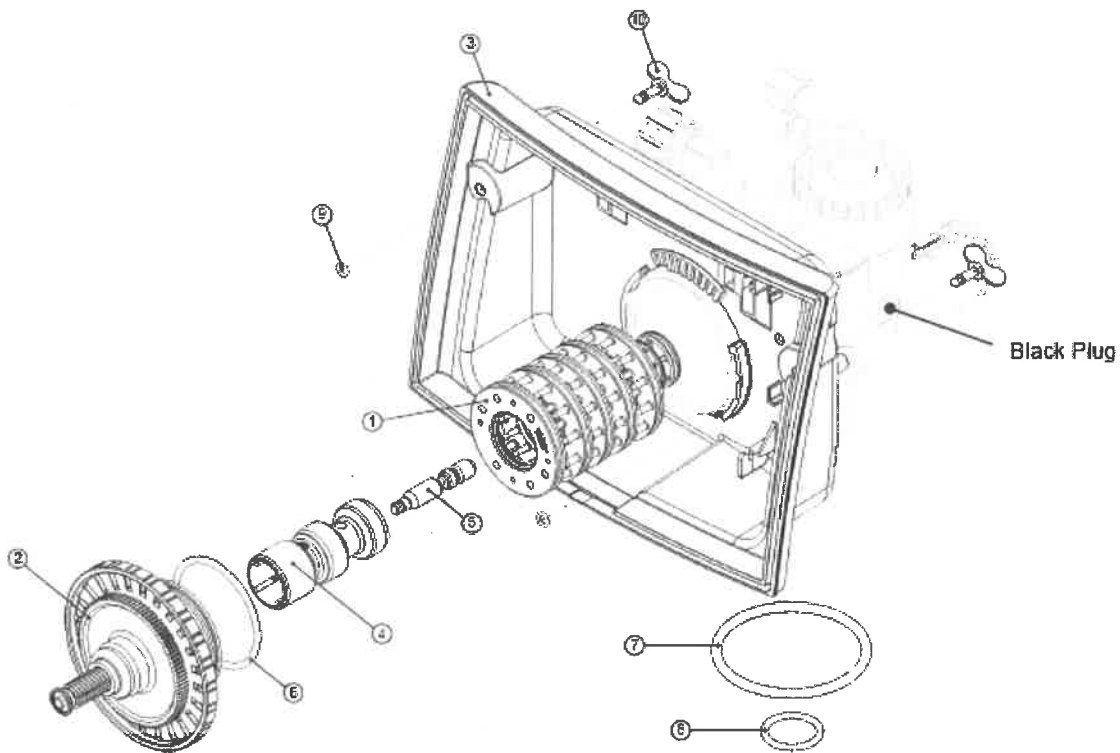

Injector Cap, Injector Screen, Injector, Plug and O-Ring

Drawing No.	Order No.	Description	Quantity
1	V3176	INJECTOR CAP	1
2	V3152	O-RING 135	1
3	V3177-01	INJECTOR SCREEN CAGE	1
4	V3010-1Z	WS1 INJECTOR ASY Z PLUG	1
5	V3010-1A	WS1 INJECTOR ASY A BLACK	1
	V3010-1B	WS1 INJECTOR ASY B BROWN	
	V3010-1C	WS1 INJECTOR ASY C VIOLET	
	V3010-1D	WS1 INJECTOR ASY D RED	
	V3010-1E	WS1 INJECTOR ASY E WHITE	
	V3010-1F	WS1 INJECTOR ASY F BLUE	
	V3010-1G	WS1 INJECTOR ASY G YELLOW	
	V3010-1H	WS1 INJECTOR ASY H GREEN	
	V3010-1I	WS1 INJECTOR ASY I ORANGE	
	V3010-1J	WS1 INJECTOR ASY J LIGHT BLUE	
V3010-1K	WS1 INJECTOR ASY K LIGHT GREEN		
Not Shown	V3170	O-RING 011	*
Not Shown	V3171	O-RING 013	*

* The injector plug and the injector each contain one 011 (lower) and 013 (upper) o-ring.

Note: For upflow position, injector is located in the up hole and injector plug is in the other hole.

WS1 and WS1.25 upflow bodies are identified by having the DN marking removed.

Upflow option is not applicable to EE, EI, or TC control valves.

For a filter that only backwashes, injector plugs are located in both holes.

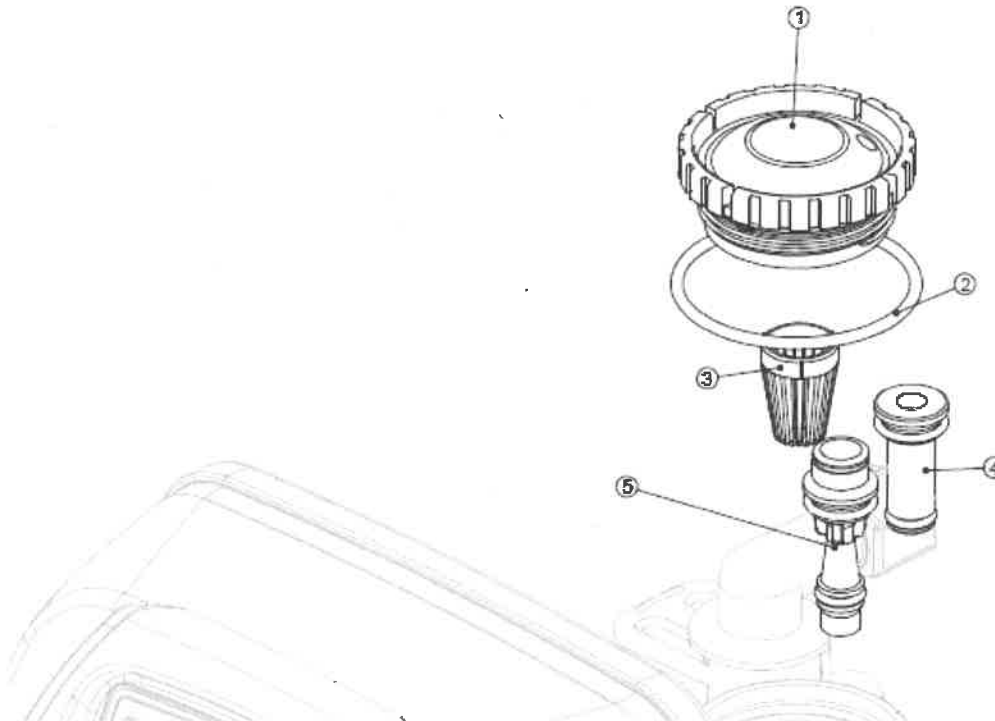

12 YEAR LIMITED WARRANTY

As of January 2017

This Residential Water Conditioner is warranted for a period of **one year** from date of purchase by first user against defects in materials and workmanship. In addition, the complete control valve is warranted for **five years**. The control valve body (excluding internals and electrical parts) is warranted for **six years**. The mineral tank, plastic brine tank or cabinet tank (excluding mineral) is warranted against rust, corrosion or bursting for a period of **twelve years** from date of manufacture. The Ozone generator is warranted for 1 year and the corona discharge cell is warranted against catastrophic electrical failure for 3 years from the date of purchase. Except, as specifically set forth in this paragraph, Master Water Conditioning Corporation makes no other warranties, express or implied.

This warranty shall be void if the conditioner is moved from the place of original installation, or if damage is caused by misuse, misapplication, accident, freezing, flood, fire or if not installed in accordance with instructions furnished by Master Water Conditioning Corporation.

This warranty shall be void in the event of damages from external sources or where the conditioner has been operated at pressure in excess of 100 pounds per square inch or at a temperature greater than 100 degrees F. or less than 32 degrees F. Incidental costs or consequential damages are not covered by this warranty.

All defective parts shall be returned prepaid to Master Water Conditioning Corporation for inspection. **Master shall not be liable for labor charges other than Master factory repairs.**

This warranty gives you specific legal rights, and you may have other rights which vary from state to state. Some states do not allow limitations on duration of implied warranties or exclusion of incidental or consequential damages, so the above limitations may not apply to you.

All claims must be submitted in writing to Master Water Conditioning Corporation at 224 Shoemaker Road, Pottstown, Pennsylvania 19464 within thirty (30) days from the discovery of the defect. Master Water Conditioning Corporation thereafter will correct defective parts and workmanship or rusting, corrosion or bursting within sixty (60) days.



224 Shoemaker Rd. Pottstown, Pa. 19464

Fusion Enhanced Oxidation Generator Annual Maintenance

In addition to standard annual maintenance of water conditioning equipment (checking injector, drain line components, etc.), the following should be done on all ozone-based filters:

1. Changing the Brine Line Check Valve.

- a. The white disc is a Kynar check valve with a Viton diaphragm. The barbed connection should just pull out of the tube. If the tube is cold and it is difficult removing it from the check valve then warming the tube with hot water will help.
- b. Disconnect the ozone tube from the corona cell.
- c. Submerge the tube end (above the check valve) into a cup of hot tap water for 3 minutes
- d. Pull tubes from the check valve and replace the check valve with the beveled side of the disc facing towards the suction ell.

2. Changing the Brine Line Check Valve and Cleaning the Corona Cell

- a. Disconnect the power connection from the ozone generator.
- b. The white disc is a Kynar check valve with a Viton diaphragm. The barbed connection should just pull out of the tube. If the tube is cold and it is difficult removing it from the check valve, then warming the tube with hot water will help.
- c. Disconnect the ozone tube from the corona cell.
- d. Submerge the tube end (above the check valve) into a cup of hot tap water for 3 minutes
- e. Remove the blue cover from the body of the black body of the ozone generator.
- f. Remove the blue pumice stone air filter, outside of the ozone generator housing, from the clear tube.
- g. Remove the zip tie on the corona cell (if present) and carefully remove the corona cell from the brackets that attach it to the board.
- h. Carefully remove the red electrical connection from the bottom of the corona cell.
- i. Disconnect the cell from the unit.

- j. The cell needs to be flushed with high purity water, either R.O., D.I., or Distilled water. Now you're ready to flush the cell.
- k. Use a bulb or large 60 cc syringe to flush water through the corona cell.
- l. Pull back on the syringe to pull water into the cell and push to flush the water out. You'll need to continue this process until the water in the cup is completely clear.
- m. Once the cell has been completely flushed and the water is clear, its time to dry the cell. Use a compressed gas duster (or computer dust spray) by placing the nozzle into one of the tubes on the cell and depressing the trigger until the moisture is gone from the cell.
- n. Pull tubes from the check valve and replace the check valve with the beveled side of the disc facing towards the suction end.
- o. Now that the Corona cell is clean, it can be reinstalled into your unit. Cleaning the corona cell can be completed quickly and will keep the unit at peak performance for years to come.

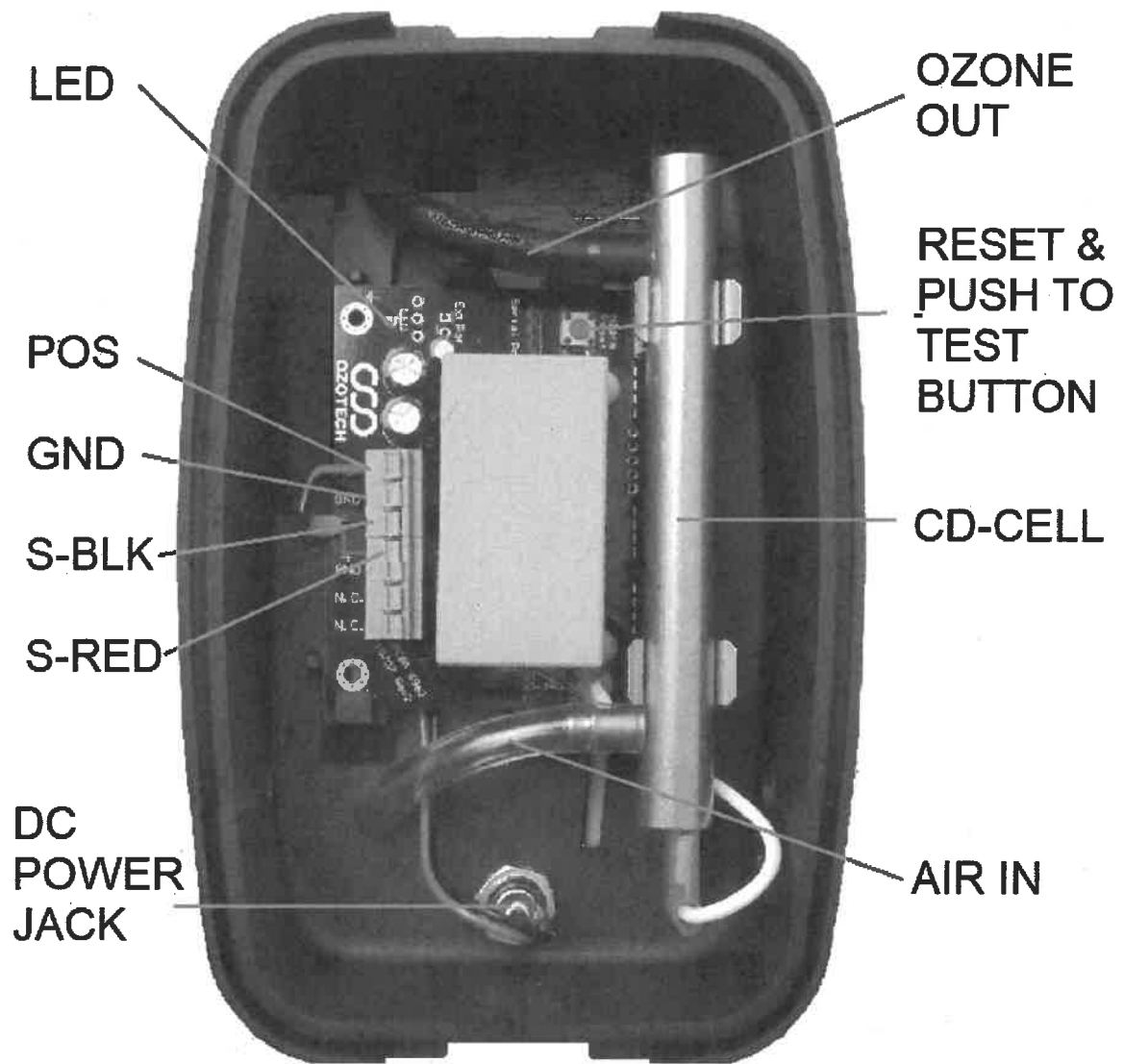

Internal Layout of Ozone Generator

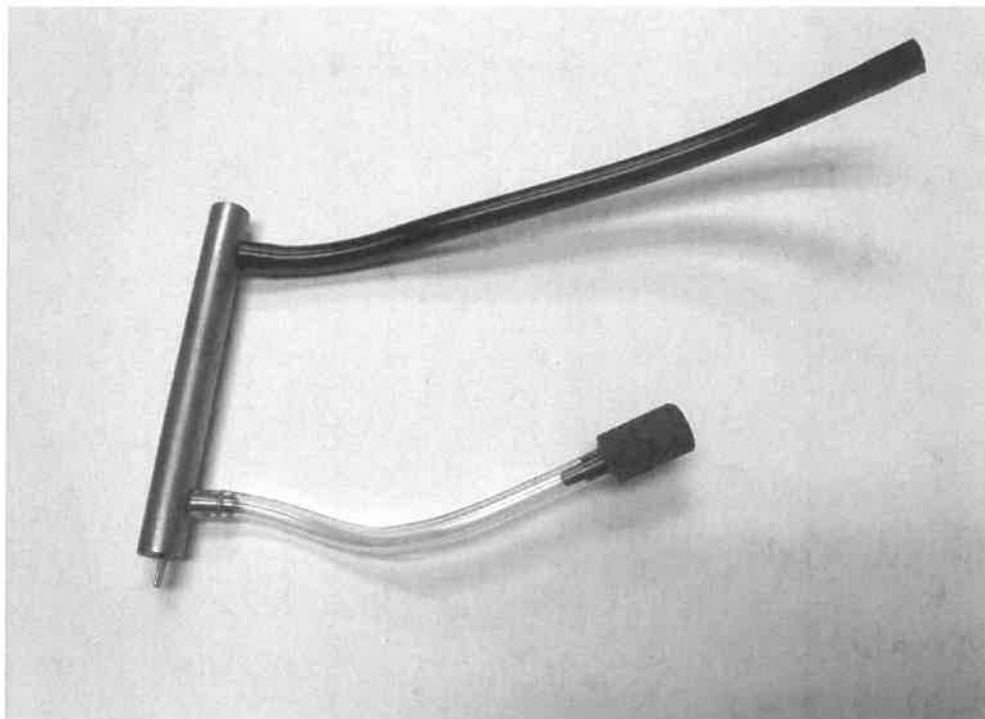

Corona Cell with Filter Stone

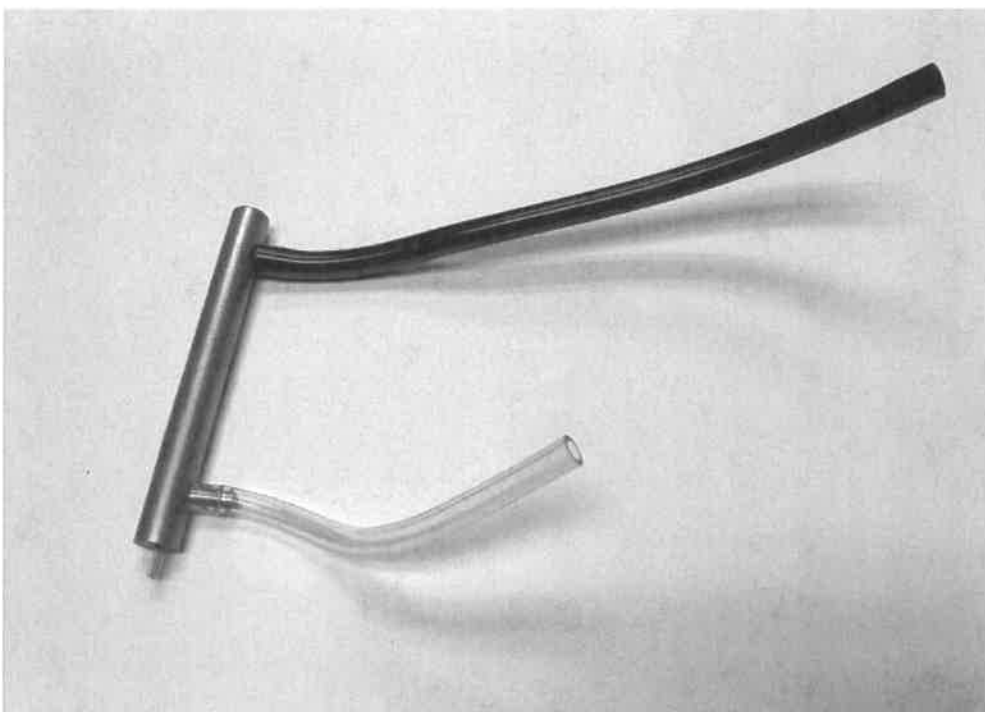

Corona Cell Without Filter Stone